

Key Specifications

- Full featured Wi-Fi 6E AP
- Tri-band access radios: 2x2:2 6GHz + 2x2:2 5GHz + 2x2:2 2.4GHz
- Up to 600 Mbps throughput for 2.4GHz radio and up to 1.2 Gbps throughput for 5GHz and 2.4 Gbps 6GHz radios
- 2x2 tri-band multi-function radio for security, network assurance and troubleshooting
- Integrated omni directional antennas
- 20/40/80/160 MHz channel width support
- Support for MU-MIMO and OFDMA
- 2x2.5 Gigabit Ethernet PoE ports
- PoE+ for full functionality
- Wall and ceiling mounting options
- BLE radio/ ZigBee*
- TPM for secure storage

Key Features

- Distributed Control Plane architecture and Flexible Data Plane
- Zero-touch deployment through automatic cloud activation and configuration
- Cloud or on-premises management plane options
- Operating modes for dedicated access, dedicated security or dual mode
- AI/ML driven diagnostics and troubleshooting
- Integrated firewall, traffic shaping, QoS and BYOD controls per SSID
- Dynamic RF optimization through smart steering, band steering and power control
- Application visibility through layer 7 deep packet inspection
- Automated device access logging
- Patented Marker Packet™ technology for rogue AP detection and classification
- Wired VLAN monitoring for “No-WiFi” zone enforcement
- Third party analytics integration with real-time data transfer
- Versatile multi-function radio for WIPS, Scanning and Client Connectivity Tests
- Self-healing wireless mesh networking

High capacity, High performance

Arista C-330 is a high-end Wi-Fi 6E enterprise grade access point featuring concurrent 6GHz, 5GHz and 2.4GHz 2 stream 802.11ax operation, integrated IoT support and an additional multi-function, tri-band radio to provide security, network assurance and enabled and AI/ML driven troubleshooting.

C-330 Capabilities

C-330 Wi-Fi 6E access point provides the high capacity and flexibility to deliver industry leading user experience in high density environments that require performance and security. Utilizing the latest technologies, Uplink/ Downlink OFDMA, Uplink/Downlink MU-MIMO coupled with 2 spatial streams in all operating bands, the C-330 delivers truly unmatched performance even in the most challenging environments. C-330 is ideal for critical, high-density networks serving a high volume of diverse clients and applications. Common deployment scenarios include large enterprises with national and international locations, university campuses and large healthcare and hospital premises.

Arista CloudVision® Managed Wi-Fi

The C-330 is an Arista CloudVision Wi-Fi managed platform. Available as a cloud service or on-premises management platform, CloudVision Wi-Fi leverages a purpose built cloud architecture delivering cloud grade analytics and automation to enterprise Wi-Fi networks. CloudVision ensures high reliability, scalability, security and cost effectiveness.

Versatile, multifunction Radio

C-330 includes a multipurpose, 2x2:2 tri-band 802.11ax radio that provides:

- Industry leading, continuous WIPS
- Better RRM decisions from continuous spectral visibility
- Network availability and performance assurance by on-demand and scheduled client connectivity test



Arista C-330

Access

C-330 is a building block of a self-driving Wi-Fi network, powering AI/ML based continued adaptations, saving time and resources resulting in significant cost savings and increased satisfaction.

- Plug and play provisioning using either Cloud or On-premises deployments - Arista Access Points take less than two minutes to activate and configure after connecting to the cloud
- Network controls like NAT, Firewall and QoS implemented at the Access Point, ensuring faster and more reliable networks
- Continuous scanning of all 2.4GHz, 5GHz and 6GHz channels by a dedicated 2x2 multi-function radio provides a dynamic, 360-degree view of the RF environment to assist in RF optimization and client handling
- Network availability and performance assurance using the multi-function third radio as a client to conduct on-demand and scheduled connectivity and performance tests
- Smart steering addresses sticky client issues by automatically pushing clients with low data rates to a better access point
- Band steering manages channel occupancy, pushing clients to the 5GHz and 6GHz channels for optimal throughput
- Smart load balancing distributes load evenly across neighbouring APs to optimize the use of network resources
- Arista Wi-Fi's distributed control plane architecture continues to serve users and secure the network even if connection with the management plane is interrupted
- Interference avoidance from LTE/3G small/macro cells/CBRS in commonly used TDD/FDD frequency bands

Security

C-330 offers complete visibility and control of the wireless airspace ensuring network integrity while actively protecting users without manual intervention.

- C-330 is equipped with industry leading fully integrated wireless intrusion prevention capabilities
- Multi-function radio provides uninterrupted spectrum scanning or client emulation for always on security coverage alongside dedicated 2.4GHz, 5GHz and 6GHz access radios
- Arista's patented Marker Packets™ help accurately detect rogue access points on any network while minimizing false positives
- Multifunction radio used as a dedicated security sensor for 24x7x365 scanning and automated over-the-air (OTA) prevention
- Deterministic rogue AP detection and prevention by monitoring all Wi-Fi and non-Wi-Fi VLANs
- OTA and on-the-wire prevention techniques assure automatic and reliable threat prevention to keep unauthorized clients and rogue APs off the network without impacting authorized connections
- Access Points autonomously scan for wireless threats and enforce security policy even if disconnected from the cloud management plane
- VLAN monitoring enables a virtual connection to non-Wi-Fi networks for complete network rogue detection and prevention

Analytics

C-330 provides real-time telemetry by granular state streaming and Cognitive Analytics provides correlation analysis and trend analysis using predictive algorithms across wireless and wired networks. Compliance and Risk analysis is supported by continuous assessment and report of deviations.

Physical Specifications

	Property	Specification
	Physical Dimensions	225mm x 225mm x 45mm/8.9" x 8.9" x 1.8"
	Weight	1.24 Kg / 2.73 lb
	Operating Temperature	0°C ~ +45°C (+32°F ~ +113°F)
	Storage Temperature	-40°C ~ +70°C (-40°F ~ +158°F)
	MTBF	@25°C - 1799429 hrs. @45°C - 821200 hrs
	Humidity	5-95% non-condensing
	Power consumption	24.35W (max)
	Processor and RAM	1GB CPU DDR, 32MB SPI Flash, 8GB EMMC
	Physical security	Kensington lock slot

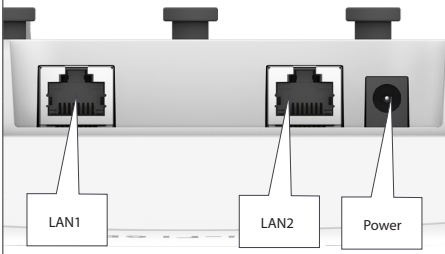
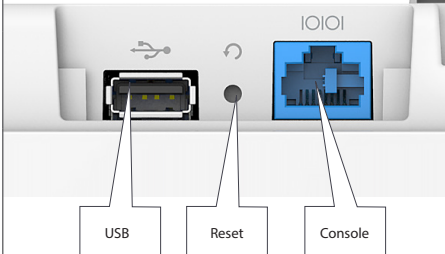
	Port	Description	Connector Type	Speed/Protocol
	Power	12V DC	5.5mm overall diameter / 2.1mm center pin hole	N/A
	LAN1	2.5GbE, PoE+ compliant, MACsec capable*	RJ-45	100M/1G/2.5G Ethernet Recommended cabling - CAT6
	LAN2	2.5GbE, PoE+ compliant, MACsec capable*	RJ-45	100M/1G/2.5G Ethernet Recommended cabling - CAT6
	Console	Establish 'config shell' terminal session via serial connection	RJ-45	RS232 Serial (115200 bps) Data bits:8; Stop bits: 1 Parity: None Flow Control: None
	USB	USB 2.0 port	USB Type-A	Future use
	Reset	Reset to factory default settings port	Pin hole push button	Let the AP boot up fully, ensure that all the LEDs are ON. Press the reset button for 15 seconds.

* MACsec capabilities will be activated via a future software update.

Operational Specifications

Input Power	12V DC (5.5mm overall diameter/2.1mm center pin hole) PoE+ <ul style="list-style-type: none"> • Full function • Hitless PoE failover between the two ethernet ports
Number of Radios	3 access radios; 2x2:2 2.4GHz, 2x2:2 5GHz and 2x2:2 6GHz radio for simultaneous tri-band access. 1 multi-function 2x2 radio for continuous WIPS and client connectivity tests 1 BLE radio
Max Clients Supported	1280 (256 clients on 2.4 GHz radio, 512 clients on 5 GHz radio and 512 clients on 6 GHz radio)
Number of Spatial Streams	2 per radio
Maximum EIRP	26.5dBm on 6GHz radio, 27.8dBm on 5GHz radio, and 25.6dBm on 2.4GHz radio (max) ¹
80+80MHz Non-Contiguous Channel Bonding	No
Bandwidth Agility	No
3G/4G Macro and Small Cells Interference Mitigation	Yes
Frequency Bands ²	2.4-2.4835 GHz, 5.15-5.25 GHz; (UNII-1), 5.25-5.35 GHz, 5.47-5.6 GHz, 5.650-5.725 GHz (UNII-2), 5.725-5.85 GHz (UNII-3), 5.925 GHz – 6.425 GHz (UNII-5), 6.425 GHz - 6.525 GHz (UNII-6), 6.525 GHz – 6.875 GHz (UNII-7), 6.875GHz - 7.125 GHz (UNII-8)
Dynamic Frequency Selection	Supported in compliance to all latest amendments from FCC, CE, IC, CB regarding certifications.

¹ Max EIRP will be restricted to Country/Regulatory domain limits

²The frequency ranges are restricted to Country/Regulatory domain limits

Wi-Fi Specifications

IEEE 802.11ax			
Frequency Band	Scanning	Transmission	
	All regions	USA & Canada (FCC/IC)	Europe (ETSI)
6GHz	5.925 GHz – 6.425 GHz 6.425 GHz - 6.525 GHz 6.525 GHz – 6.875 GHz 6.875GHz - 7.125 GHz	5.925 GHz – 6.425 GHz 6.425 GHz - 6.525 GHz 6.525 GHz – 6.875 GHz 6.875GHz - 7.125 GHz	5.925 GHz – 6.425 GHz
Modulation Type	OFDM / OFDMA		
Peak Data Rate	2.4 Gbps		
Antenna	Integrated modular high efficiency PIFA antenna x2 (peak gain 6 dBi)		

IEEE 802.11a/n/ac/ax			
Frequency Band	Scanning	Transmission	
	All regions	USA & Canada (FCC/IC)	Europe (ETSI)
5GHz	5.15 - 5.25 GHz 5.25 - 5.35 GHz 5.47 - 5.725 GHz 5.725 - 5.825 GHz	5.15 - 5.25 GHz 5.25 - 5.35 GHz 5.725 - 5.825 GHz	5.15 - 5.25 GHz 5.25 - 5.35 GHz 5.47 - 5.725 GHz
Modulation Type	DSSS / OFDM / OFDMA		
Peak Data Rate	1.2 Gbps		
Antenna	Integrated modular high efficiency PIFA antenna x2 (peak gain 5.3dBi)		

IEEE 802.11b/g/n/ax			
Frequency Band	Scanning	Transmission	
	All regions	USA & Canada (FCC/IC)	Europe (ETSI)
2.4GHz	2.4 – 2.4835 GHz	2.4 – 2.4735 GHz	2.4 – 2.4835 GHz
Modulation Type	DSSS / OFDM / OFDMA		
Peak Data Rate	600 Mbps		
Antenna	Integrated modular high efficiency PIFA antenna x2 (peak gain 4.8dBi)		

Receive Sensitivity

2.4GHz

Mode	Rate	Sensitivity (dBm)
802.11g	6 Mbps	-90
	54 Mbps	-73
802.11n_HT20	MCS 0	-90
	MCS 4	-80
	MCS 7	-73
802.11n_HT40	MCS 0	-87
	MCS 4	-77
	MCS 7	-69
802.11n_VHT20	MCS 0	-90
	MCS 4	-80
	MCS 8	-69
802.11n_VHT40	MCS 0	-87
	MCS 4	-77
	MCS 9	-65
802.11n_HE20	MCS 0	-90
	MCS 4	-79
	MCS 7	-72
	MCS 9	-66
	MCS 11	-58
802.11n_HE40	MCS 0	-87
	MCS 4	-77
	MCS 7	-69
	MCS 9	-64
	MCS 11	-58

5GHz

Mode	Rate	Sensitivity (dBm)
802.11a	6 Mbps	-90
	54 Mbps	-74
802.11n_HT20	MCS 0	-91
	MCS 4	-80
802.11n_HT40	MCS 0	-88
	MCS 4	-78
	MCS 7	-70
802.11ac_VHT20	MCS 0	-91
	MCS 4	-80
	MCS 8	-69
802.11ac_VHT40	MCS 0	-88
	MCS 4	-78
	MCS 9	-65
802.11ac_VHT80	MCS 0	-86
	MCS 4	-75
	MCS 9	-62
802.11ax_HE20	MCS 0	-90
	MCS 4	-79
	MCS 7	-72
	MCS 11	-60
802.11ax_HE40	MCS 0	-88
	MCS 4	-77
	MCS 7	-70
	MCS 9	-64
	MCS 11	-58
802.11ax_HE80	MCS 0	-86
	MCS 4	-75
	MCS 7	-67
	MCS 9	-62
	MCS 11	-56

6GHz

Mode	Rate	Sensitivity (dBm)
Legacy	6 Mbps	-93
	54 Mbps	-76
802.11ax_HE20	MCS 0	-92
	MCS 4	-83
	MCS 7	-76
	MCS 9	-69
802.11ax_HE40	MCS 11	-65
	MCS 0	-89
	MCS 4	-80
802.11ax_HE80	MCS 7	-73
	MCS 9	-67
	MCS 11	-62
	MCS 0	-86
802.11ax_HE160	MCS 4	-77
	MCS 7	-70
	MCS 9	-64
	MCS 11	-59
802.11ax_HE160	MCS 0	-84
	MCS 4	-74
	MCS 7	-67
	MCS 9	-62
	MCS 11	-56

Maximum EIRP

2.4GHz

Mode	Rate	Power (dBm)
802.11b	1 Mbps	25.6
	11 Mbps	25.6
802.11g	6 Mbps	25.6
	54 Mbps	23.1
802.11n_HT20	MCS 0	25.4
	MCS 4	25
	MCS 7	22.9
802.11n_HT40	MCS 0	25
	MCS 4	24.2
	MCS 7	22.6
802.11ac_VHT20	MCS 0	25.3
	MCS 4	24.7
	MCS 8	22.3
802.11ac_VHT40	MCS 0	25.1
	MCS 4	24.5
	MCS 9	22.2
802.11ax_HE20	MCS 0	24.9
	MCS 4	24.6
	MCS 7	22.7
	MCS 9	22.3
	MCS 11	21.8
802.11ax_HE40	MCS 0	24.8
	MCS 4	24.2
	MCS 7	22.5
	MCS 9	22
	MCS 11	21.6

5GHz

Mode	Rate	Power (dBm)
802.11a	6 Mbps	27.8
	54 Mbps	25.8
802.11n_HT20	MCS 0	27.5
	MCS 4	27
	MCS 7	24.9
802.11n_HT40	MCS 0	27.1
	MCS 4	26.3
	MCS 7	23.9
802.11ac_VHT20	MCS 0	27.6
	MCS 8	26.9
802.11ac_VHT40	MCS 0	27.1
	MCS 4	26.3
	MCS 9	23.7
802.11ac_VHT80	MCS 0	27.1
	MCS 4	26.3
	MCS 9	23.8
802.11ax_HE20	MCS 0	27.4
	MCS 4	26.9
	MCS 7	24.7
	MCS 9	23.7
	MCS 11	22.8
802.11ax_HE40	MCS 0	26.8
	MCS 4	26.3
	MCS 7	24.3
	MCS 9	23.7
	MCS 11	22.8
802.11ax_HE80	MCS 0	26.6
	MCS 4	26.2
	MCS 7	24.2
	MCS 9	23.7
	MCS 11	22.7

6GHz

Mode	Rate	Power (dBm)
Legacy	6M	26.2
	54M	25.5
802.11ax_HE20	MCS 0	26.3
	MCS 4	26.5
	MCS 7	25.4
	MCS 9	24.9
	MCS 11	23.8
802.11ax_HE40	MCS 0	26.4
	MCS 4	26.5
	MCS 7	25.5
	MCS 9	25.1
	MCS 11	24
802.11ax_HE80	MCS 0	26.7
	MCS 4	26.5
	MCS 7	25.4
	MCS 9	24.9
	MCS 11	23.9
802.11ax_HE160	MCS 0	26.5
	MCS 4	25.4
	MCS 7	23.3
	MCS 9	22.3
	MCS 11	21.8

Radiation Pattern

Radio 1: 2.4GHz

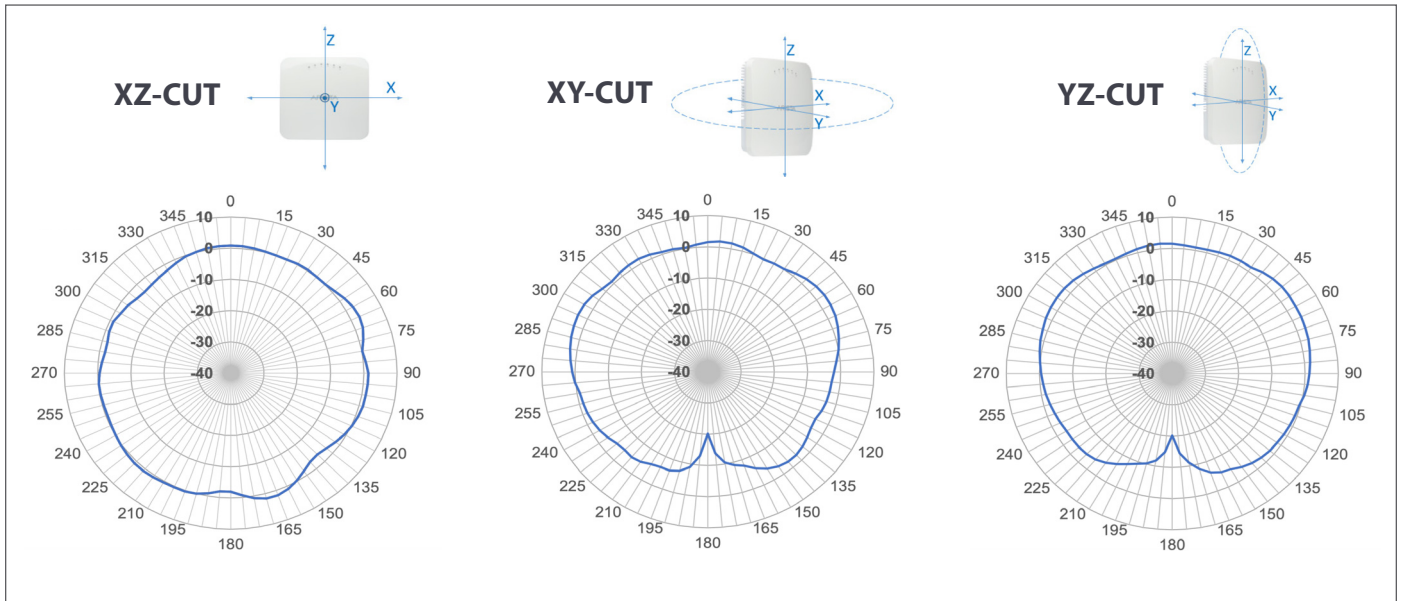

Radio 2: 5GHz

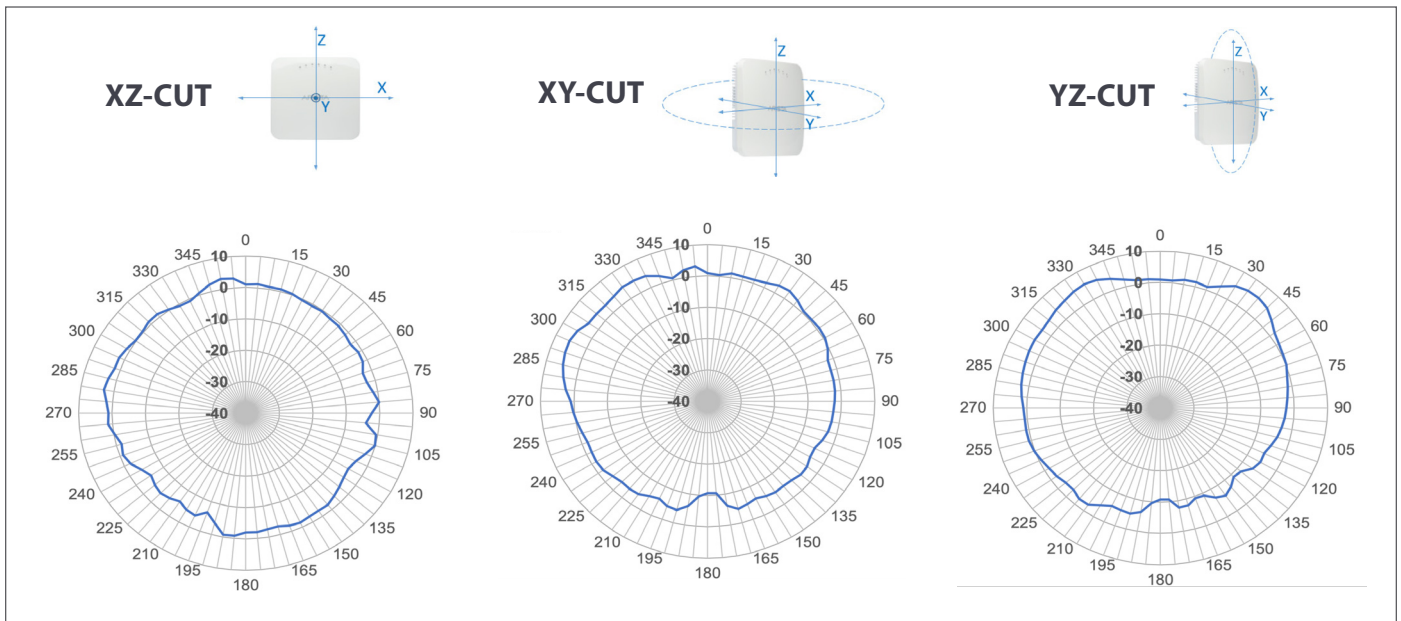

Radio 3: 6GHz

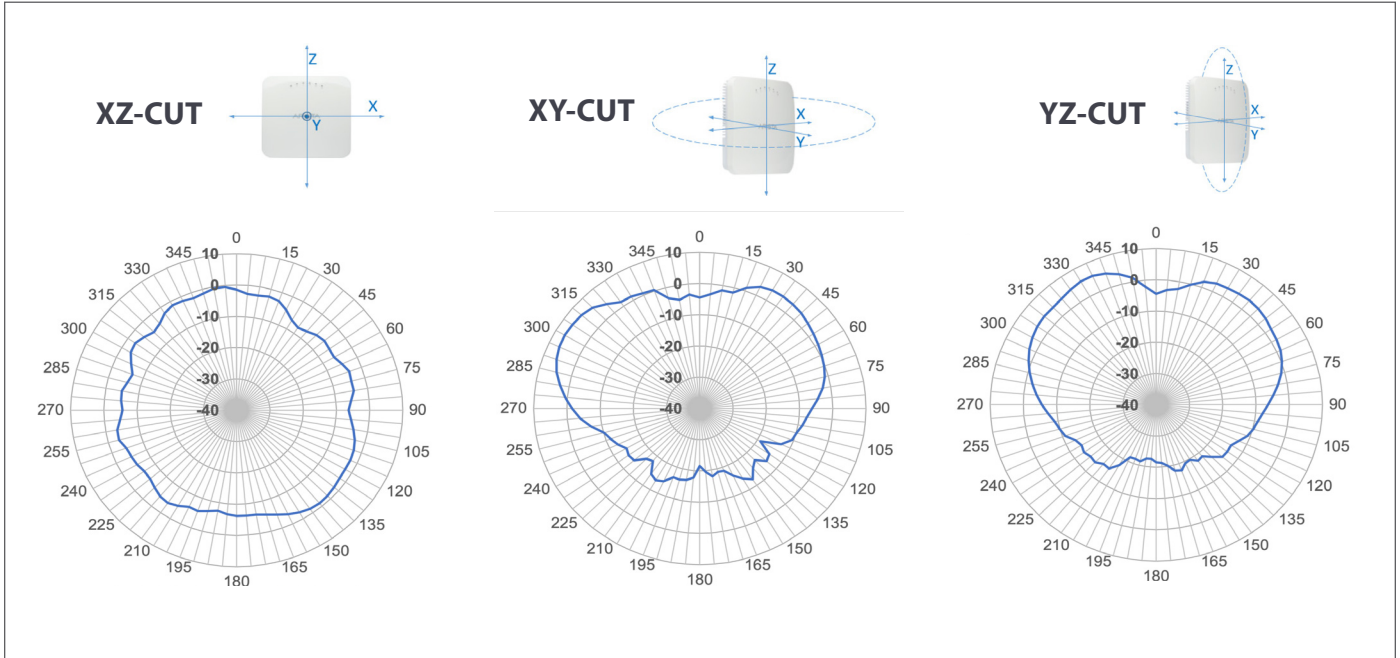

Regulatory Specifications

RF and Electromagnetic Compatibility (EMC)

Country	Certification
USA	FCC Part 15.247, Part 15.407, 15B
Canada	RSS-102, RSS-210, RSS-247, RSS-248, ICES-003 ISSUE 07
Europe	EN 300 328, EN 300 440, EN 301 893, EN 62311, EN 50385, EN 301 489-1, EN 55032, EN 55035, EN 18031-1:2024, Draft EN 303 687 CISPR 35, CISPR 32. Countries covered under Europe certification: Austria, Belgium, Bulgaria, Croatia, Cyprus, Czechia, Denmark, Estonia, Finland, France, Germany, Greece, Hungary, Ireland, Italy, Latvia, Lithuania, Luxembourg, Malta, the Netherlands, Poland, Portugal, Romania, Slovakia, Slovenia, Spain, Sweden, United Kingdom.

*For complete country certification records, please visit the site: <https://www.arista.com/en/support/product-certificate>

Safety & Environmental

Country	Certification
USA, Canada	UL62368-1, 3 rd Edition; CAN/CSA C22.2 No 62368-1:19, UL 2043
European Union (EU)	IEC/EN 62368-1 2nd edition
Taiwan	CNS 15598-1, CNS 15663 RoHS
International	IEC 62368-1: 2018

Ordering Information

Access Point

Part Number	Description
AP-C330	C-330 tri-band 2x2 Wi-Fi 6E access point with internal antennas
AP-C330-SS-5Y	C-330 AP with 5 years bundled Cognitive Cloud SW subscription
AP-C330-SS-3Y	C-330 AP with 3 years bundled Cognitive Cloud SW subscription

Mounting Options

For details of mounting options, see the Access Points [Mounting Brackets Guide](#)

Power

Part Number	Description
PWR-AP-W4	Universal AC power supply for C-330, 12VDC, 3.3A

Headquarters

5453 Great America Parkway
Santa Clara, California 95054
408-547-5500

Support

support@arista.com
408-547-5502
866-476-0000

Sales

sales@arista.com
408-547-5501
866-497-0000

www.arista.com

ARISTA