

APC™ Smart-UPS™ Ultra 5 kVA SRTL 5KRM 2UT/2UT-HW/2UI/2UI-HW/ 2UJ/2UJ-HW

Important Safety Instructions

SAVE THESE INSTRUCTIONS - This manual contains important instructions that should be followed during installation and maintenance of the Smart-UPS and batteries.



This is the “Read user manual” symbol. Read the user documentation to become familiar with the equipment.

Read these instructions carefully and look at the equipment to become familiar with the device before trying to install or operate it.

The following special messages may appear throughout this bulletin or on the equipment to warn of potential hazards or to call attention to information that clarifies or simplifies a procedure.



The addition of this symbol either to a “Danger” or “Warning” safety label indicates that an electrical hazard exists which will result in personal injury if the instructions are not followed.



This is the safety alert symbol. It is used to alert you to potential personal injury hazards. Obey all safety messages that follow this symbol to avoid possible injury or death.

DANGER

DANGER indicates a hazardous situation which, if not avoided, **will result** in death or serious injury.

WARNING

WARNING indicates a hazardous situation which, if not avoided, **could result** in death or serious injury.

CAUTION







CAUTION indicates a hazardous situation which, if not avoided, **could result** in minor or moderate injury.

NOTICE

NOTICE is used to address practices not related to physical injury.

Electrical equipment should be installed and operated only by qualified personnel. No responsibility is assumed by Schneider Electric for any consequences arising out of the use of this material.

Product Handling Guidelines

					
<18 kg <40 lb	18-32 kg 40-70 lb	32-55 kg 70-120 lb	>55 kg >120 lb		

Safety and General Information

- Adhere to all national and local electrical codes.
- All wiring must be performed by a qualified electrician.
- Changes and modifications to this unit not expressly approved by Schneider Electric could void the warranty.
- This UPS is only for Professional Business Applications and not for Consumer Applications.
- This UPS is intended for indoor use only.
- This UPS must be installed in dedicated IT environments only.
- Do not operate this UPS in direct sunlight, in contact with fluids, or where there is excessive dust or humidity.
- Be sure the air vents on the UPS are not blocked. Allow adequate space for proper ventilation.
- For a UPS with a factory installed power cord, connect the UPS power cable directly to a wall outlet. Do not use surge protectors or extension cords.
- The equipment is heavy. Always practice safe lifting techniques adequate for the weight of the equipment.
- The battery modules are heavy. Remove the battery modules before installing the UPS and external battery packs (XLBPs), in a rack.
- Be sure that the depth of the rack is at least 1070 mm.
- Be sure that a clear space of 300 mm (minimum), for ventilation, is available from the front and rear surfaces
 - of the rack, when the UPS is installed in a rack.
 - of the UPS, when the UPS is installed in tower orientation.
- Always install XLBPs at the bottom in rack-mount configurations. The UPS must be installed above the XLBPs.
- Always install peripheral equipment above the UPS in rack-mount configurations.
- Additional safety information can be found in the Safety Guide supplied with this unit.
- This UPS must be serviced by service personnel or a qualified electrician.

Deenergizing Safety

- The UPS contains internal battery modules and may present a shock hazard even when disconnected from AC and DC power.
- Before installing the UPS or any accessory be sure that the:
 - Mains circuit breaker is in **OFF** position or the UPS is disconnected from AC source
 - Internal UPS battery modules are removed
 - XLBP(s) is(are) disconnected

Electrical Safety

- Do not handle any metallic connector before power has been disconnected.
- For models with a hardwired input, the connection to the branch circuit (mains) must be performed by a qualified electrician.
- **2UI and 2UI-HW models only:** In order to comply with the EMC regulations, output cords and network cables attached to the UPS must not exceed 10 meters in length.
- The protective earth conductor for the UPS carries the leakage current from the load devices (computer equipment). An insulated ground conductor is to be installed as part of the branch circuit that supplies input power to the UPS. The conductor must have the same size and insulation material as the grounded and ungrounded branch circuit supply conductors. The conductor will typically be green and with or without a yellow stripe.
- The UPS input ground conductor must be properly bonded to protective earth at the service panel. If the UPS input power is supplied by a separately derived system, the ground conductor must be properly bonded at the supply transformer or motor generator set.
- Connect only SELV circuits to all the communication ports.

Battery Safety



WARNING

RISK OF CHEMICAL HAZARD AND EXCESSIVE SMOKE

- Replace the battery modules at least every 10 years or at the end of its service life, whichever is earlier.
- Replace the battery modules immediately when the UPS indicates battery replacement is necessary.
- Replace the battery modules with the same number as originally installed in the equipment.

Failure to follow these instructions can result in death or serious injury.

- Schneider Electric uses Lithium Ion batteries. Under normal use and handling, there is no contact with the internal components of the battery.
- The replaceable battery module (RBM) typically lasts for 10 years. Environmental factors impact battery life. Elevated ambient temperatures, poor quality mains power causing frequent short duration discharges will shorten battery life.
- CAUTION: Before installing or replacing the RBM, remove conductive jewelry such as chains, wrist watches and rings. High energy through conductive materials could cause severe burns.
- CAUTION: Do not place or use the RBM or XLBP near heat or fire. Do not crush, do not dispose off a RBM or XLBP in a fire. The batteries may explode..
- CAUTION: Do not open the enclosure of RBM. Doing so will expose the cell terminals which pose an energy hazard.
- CAUTION: Do not open the RBM or mutilate the cells inside. Released chemical is harmful to the skin and eyes. It may be toxic.
- CAUTION: RBM can present a risk of electric shock and burns by high short-circuit current.
- CAUTION: Failed RBMs can reach temperatures that exceed the burn thresholds for touchable surfaces.

- Do not use a dropped, damaged or deformed RBM.
- Do not short circuit the RBM.
- Do not drive nails into the RBM.
- Do not strike the RBM with a hammer.
- The XLBPs should be replaced by qualified personnel only.
- The RBMs can be replaced by the user.
NOTE: Live swap of RBM should be performed by qualified personnel only.

Hardwire Safety

- Verify that all branch circuit (mains) and low voltage (control) circuits are de-energized, and locked out before installing cables or making connections, whether in the junction box or to the UPS.
- Wiring must be done only by a qualified electrician.
- Check national and local codes before wiring.
- Strain relief is required for all hardwiring (supplied with select products). Snap in type strain reliefs are recommended.
- All openings that allow access to UPS hardwire terminals must be covered. Failure to do so may result in personal injury or equipment damage.
- Select wire size and connectors according to national and local codes.

Physical Site Security

Recommendations to secure the site, to prevent physical attacks:

- Secure the front panel of your device and deploy the device in a secure location.
- Secure the front panel by installing the device inside cabinets or the device is protected by physical restraints that prevent unauthorized access or removal from restricted areas. Cabinets should be locked with a suitable key or other physical methods.

To secure the location (restricted area):

- Clearly mark the restricted area “for authorized personnel only”.
- Lock the doors to the restricted area.
- Grant access to restricted areas only to such personnel based on their job function.
- Give minimum indication of the purpose of the covered devices in restricted areas without identifying the presence of related functions.
- Provide control devices (for physical access), such as key card readers, locks for doors and cabinets. These physical access control devices should be tested before putting them to use as well as periodically.
- Be sure that resource custodian is able produce physical or electronic audit trails to record all personnel’s physical access to restricted areas for security incident investigation.
- Regularly review inventory of personnel having physical access to control devices and promptly remove any inappropriate access identified during such reviews.
- Consider physical security of cabling when insecure protocols like Modbus TCP are used.

General Information

- The UPS will recognize as many as 10 XLBPs connected to the UPS.
NOTE: For each XLBP added, recharge time will increase.
- The model and serial numbers are located on a top cover label. For some models, an additional label is located on the chassis under the front bezel.
- Always recycle used RBMs.
- Recycle the package materials or save them for reuse.

FCC Class A Radio Frequency Warning

NOTE: Applicable only for SRTL5KRM2UT and SRTL5KRM2UT-HW models.

This equipment has been tested and found to comply with the limits for a Class A digital device, pursuant to part 15 of the FCC Rules. These limits are designed to provide reasonable protection against harmful interference when the equipment is operated in a commercial environment. This equipment generates, uses, and can radiate radio frequency energy and, if not installed and used in accordance with the instruction manual, may cause harmful interference to radio communications. Operation of this equipment in a residential area is likely to cause harmful interference in which case the user will be required to correct the interference at his own expense.

Radio Frequency Warning

NOTE: Applicable only for SRTL5KRM2UI and SRTL5KRM2UI-HW models.

WARNING: This is a category C2 UPS product. In a residential environment, this product may cause radio interference, in which case the user may be required to take additional measures.

VCCI-A Caution

NOTE: Applicable only for SRTL5KRM2UJ and SRTL5KRM2UJ-HW models.

この装置は、クラスA機器です。この装置を住宅環境で使用すると電波妨害を引き起こすことがあります。この場合には使用者が適切な対策を講ずるよう要求されることがあります。

VCCI-A

SURT15a

Package Contents

Inspect the contents upon receipt. Notify the carrier and dealer if the unit is damaged.

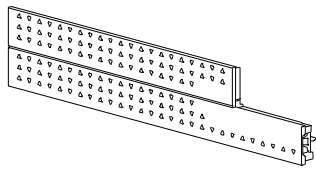
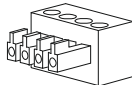
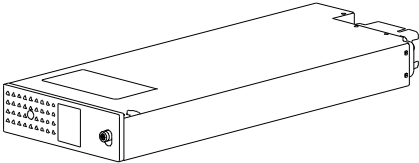
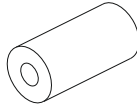
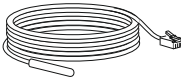
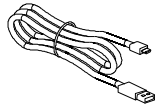
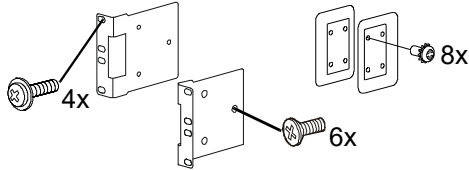
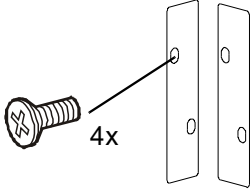
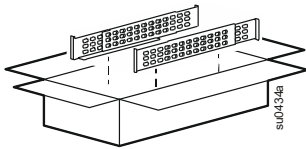
Included with all models	
<p>Front bezel</p> 	<p>EPO Terminal block</p> 
<p>Battery module</p> 	<p>Ferrite Bead</p>  <p>Temperature sensor probe</p>  <p>USB cable</p> 
<ul style="list-style-type: none"> • 1 pair cleat • 8 pan head screws to secure cleat to the UPS • 1 pair rack-mount brackets • 6 flat head screws to secure rack-mount brackets to the UPS • 4 ornamental screws to secure rack-mount brackets to the rails 	<ul style="list-style-type: none"> • 1 pair stabilizer brackets • 4 flat head screws to secure tower stabilizer brackets to the UPS 
<p>Rail Kit with instructions and hardware for installing rails in a rack.</p> 	

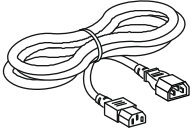
Included only with SRTL5KRM2UI	
<p>2 output power cords:</p> <ul style="list-style-type: none"> • 1.2 m in length - 1x • 2 m in length - 1x <p>NOTE: These power cords should only be used to connect the load to the UPS. Do not use these power cords for other connections.</p>	

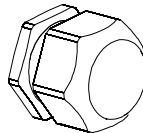
Included with SRTL5KMR2UI/SRTL5KRM2UI-HW/SRTL5KRM2UJ-HW/SRTL5KRM2UT-HW	
<p>Strain relief</p> <ul style="list-style-type: none"> • 1x with SRTL5KRM2UI/SRTL5KRM2UT-HW/SRTL5KRMUJ-HW • 2x with SRTL5KRM2UI-HW 	

Specifications

For additional specifications visit our web site, www.apc.com.

Environmental

Temperature	Operating	0 to 40 °C (32 to 104 °F)
	Storage	-15 to 45 °C (5 to 113 °F)
Maximum Elevation	Operating	0 - 3,000 m (0 - 10,000 ft)
	Storage	0 - 15,000 m (50,000 ft)
Humidity		0% to 95% relative humidity, non-condensing
International Protection Code		IP20
Pollution Degree[†]		PD2

NOTES:

- Charge the RBMs immediately upon receipt / first installation and at least once in nine months during storage or when not in use.
- Environmental factors impact battery life. Elevated ambient temperatures, high humidity, poor quality mains power causing frequent short duration discharges will shorten battery life.

[†]Applicable for SRTL5KRM2UI and SRTL5KRM2UI-HW models only.

Physical

NOTE: The UPS is heavy. Follow all lifting guidelines.

	SRTL5KRM2UT SRTL5KRM2UT-HW SRTL5KRM2UJ SRTL5KRM2UJ-HW	SRTL5KRM2UI SRTL5KRM2UI-HW
Unit weight without packaging (approx.)	30 kg (66.14 lb)	27.2 kg (60 lb)
Unit weight with packaging (approx.)	41 kg (90.40 lb)	38.5 kg (84.88 lb)
Unit dimensions without packaging Height x Width x Depth	86 x 432 x 795 [†] mm (3.4 x 19 x 31.3 in)	
Unit dimensions with packaging Height x Width x Depth	392 x 585 x 984 mm (15.43 x 23.03 x 38.74 in)	

[†] includes the diameter of recommended cable and supplied strain relief for SRTL5KRM2UI and SRTL5KRM2UI-HW models.

Battery

Battery type	Lithium-Ion
Replacement battery module This UPS has replaceable battery modules. Refer to the appropriate replacement battery user manual for installation instructions. Contact your dealer or go our web site, www.apc.com for information on replacement batteries.	SRYLBM
Number of battery modules Battery module voltage Ah rating	1 180 V 4 Ah per battery module Usable: 2.47 Ah

Battery module	UPS	XLBP
SRYLBM	SRTL5KRM2UI SRTL5KRM2UI-HW SRTL5KRM2UT SRTL5KRM2UT-HW	SRTL180RM2UBP
	SRTL5KRM2UJ SRTL5KRM2UJ-HW	SRTL180RM2UBPJ

NOTE: If the battery pack is healthy and the communication is enabled, the **Battery module status** LED on the front panel of the battery pack illuminates Green else it illuminates Red.

Electrical

CAUTION: To reduce the risk of fire, connect the UPS only to a circuit provided with recommended maximum branch circuit overcurrent protection in accordance with the National Electrical Code, ANSI/NFPA 70 and the Canadian Electrical Code, Part I, C22.1.

Model	Rating		Branch Circuit Overcurrent Rating / Building Circuit Breaker (CB) Current Rating †
	Online	Green Mode	
SRTL5KRM2UI SRTL5KRM2UI-HW	5 kVA / 5 kW	5 kVA	40 A
SRTL5KRM2UT SRTL5KRM2UT-HW	208 V 4.9 kVA / 4.9 kW 240 V 5 kVA / 5 kW	4.9 kVA 5 kVA	30 A
SRTL5KRM2UJ SRTL5KRM2UJ-HW	5 kVA / 4.6 kW	5 kVA	

† If you intend to install an Earth Leakage Circuit Breaker (ELCB) instead, contact your local Schneider Electric customer support for the rating of the ELCB.

NOTE: The following specifications are applicable only for SRTL5KRM2UI and SRTL5KRM2UI-HW model.

Over Voltage Category	OVC II
Applicable power grid power distribution system	TN Power System
Applicable Standard	IEC 62040-1 / UL1778

Output

Model	SRTL5KRM2UI SRTL5KRM2UI-HW	SRTL5KRM2UT SRTL5KRM2UT-HW	SRTL5KRM2UJ SRTL5KRM2UJ-HW
Output Frequency	50/60 Hz ± 3 Hz		
Nominal Output Voltage	220/230/240 VAC	208/240 VAC	200 VAC

Input



Model	SRTL5KRM2UI SRTL5KRM2UI-HW	SRTL5KRM2UT SRTL5KRM2UT-HW	SRTL5KRM2UJ SRTL5KRM2UJ-HW
Input Frequency	40 to 70 Hz ± 0.1 Hz		
Nominal Input Voltage	220/230/240 VAC	208/240 VAC	200 VAC

Hardwiring

Input Connections

SRTL5KRM2UI SRTL5KRM2UI-HW	Connect wires to Line (L), Neutral (N), Protective Earth 
-------------------------------	--

Output Connections

SRTL5KRM2UT-HW SRTL5KRM2UJ-HW	Connect wires to Line1 (L1), Line2 (L2), and Earth 
SRTL5KRM2UI-HW	Connect wires to Line (L), Neutral (N), and Earth 

Wire Size

Model	Input wire size, (typical)	Output wire size, (typical)
SRTL5KRM2UI SRTL5KRM2UI-HW	6 mm ²	6 mm ²
SRTL5KRM2UT-HW SRTL5KRM2UJ-HW	L6-30 [†]	

[†] L6-30 power cords are inbuilt.

Rack-Mount Installation

Refer to the Rail Kit Installation Guide for instructions on rail installation.

NOTE: Be sure to mount the UPS in rack having a minimum depth of 1070 mm.

CAUTION

RISK OF FALLING EQUIPMENT

- The equipment is heavy. Always practice safe lifting techniques adequate for the weight of the equipment.
- Always use the recommended number of screws to secure brackets to the UPS.
- Always use the recommended number of screws and cage nuts to secure the UPS to the rack.
- Always install the UPS at the bottom of the rack.
- Always install the external battery pack below the UPS in the rack.
- Place the rack in the location where the equipment will be used.
- Do not move the rack once the UPS is installed.

Failure to follow these instructions can result in equipment damage and minor or moderate injury.

- 1** Install the cleats and rack-mount brackets to the UPS with the screws supplied.

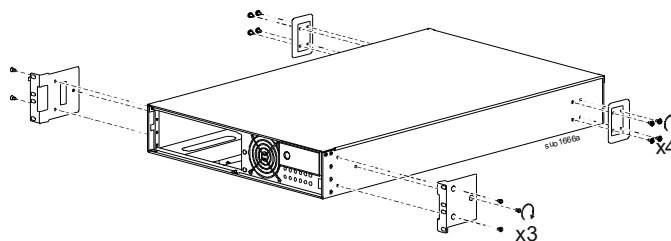

- 2** Lift the UPS and slide it into the rack enclosure.

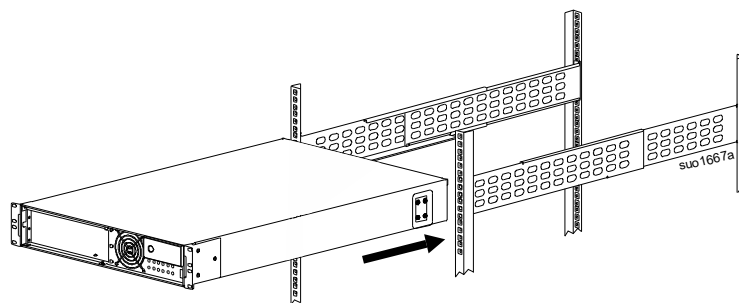

- 3** Secure the UPS to the rack with the screws supplied.

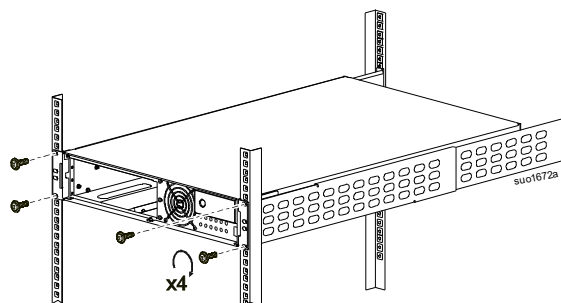

- 4** 1. Slide the battery module till it gets fully inserted into the UPS.
 2. Press the thumbscrew till it engages and turn the thumbscrew clockwise to lock the battery and enable battery communication.
NOTE: If the thumbscrew does not engage, then push the battery module further into the UPS till it gets fully inserted.

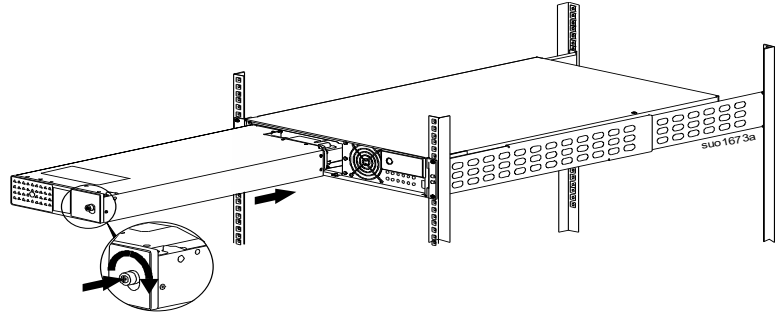

- 5** Rotate the BATTERY ON/OFF switch in counter clockwise direction to turn on the battery module.

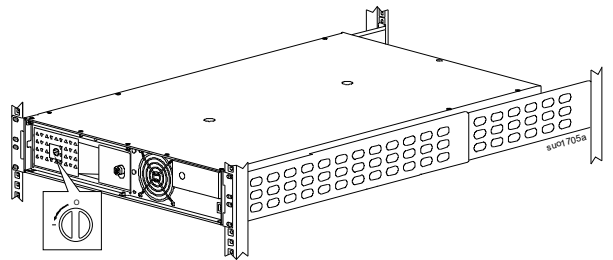

- 6** Install the bezel.

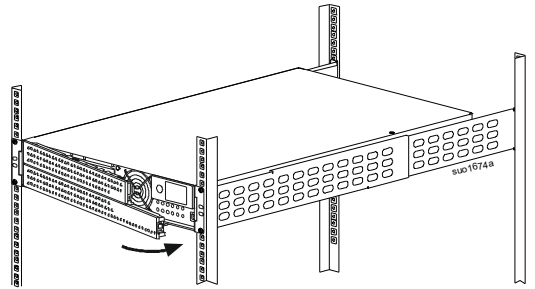

Tower Installation

⚠ CAUTION

RISK OF FALLING EQUIPMENT

- The equipment is heavy.
- Always practice safe lifting techniques adequate for the weight of the equipment.

Failure to follow these instructions can result in equipment damage and minor or moderate injury.

1 Install the stabilizer brackets.

2 Turn the UPS right side up.

3

1. Slide the battery module till it gets fully inserted into the UPS.
2. Press the thumbscrew till it engages and turn the thumbscrew clockwise to lock the battery and enable battery communication.

NOTE: If the thumbscrew does not engage, then push the battery module further into the UPS till it gets fully inserted.

4 Rotate the BATTERY ON/OFF switch in counter clockwise direction to turn on the battery module.

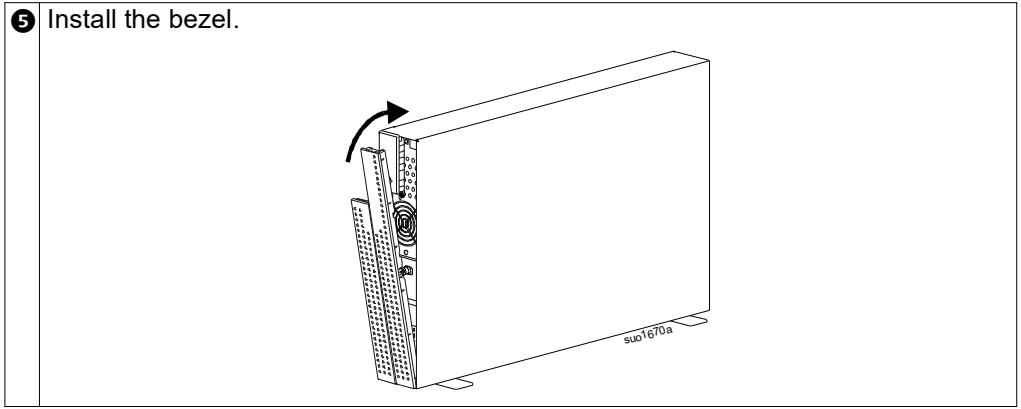

Front panel features

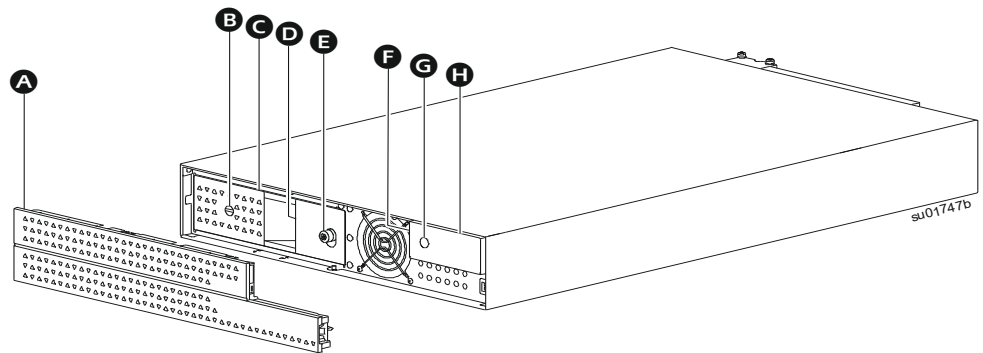

A	Bezel
B	BATTERY ON/OFF switch
C	Battery module
D	Battery status LED (located behind the battery handle)
E	Thumbscrew
F	UPS Status LED Indicator (located on the side wall of the LCD display)
G	POWER ON button
H	LCD Display

Rear panel features

NOTES:

Refer to the table “Key to identify rear panel features” on page 15, that provides a key to the call-out numbers for the rear panel graphics depicted in this manual.

The illustrations are only for reference. The actual features of the rear panel may vary depending on the model.

SRTL5KRM2UI

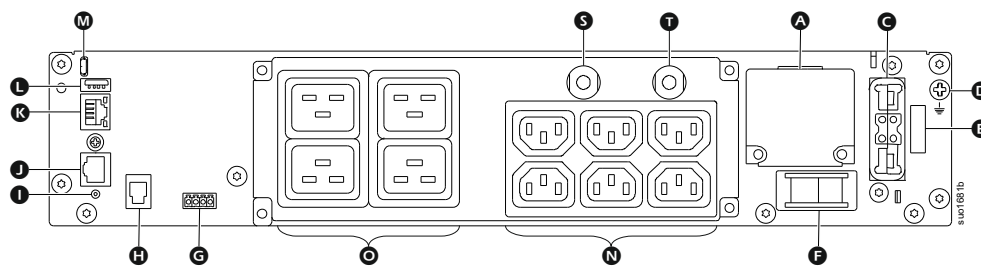

SRTL5KRM2UT

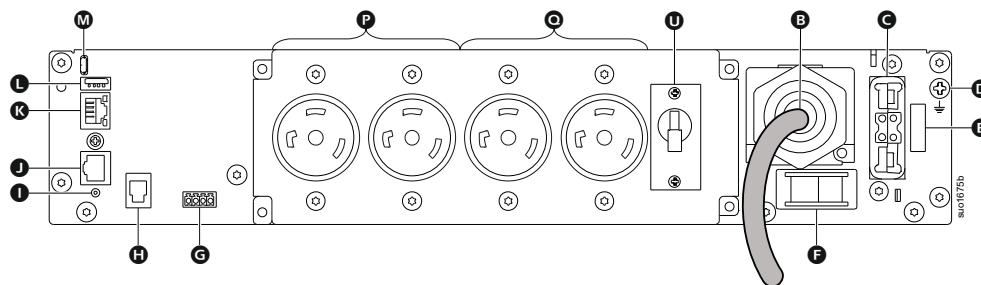

SRTL5KRM2UJ

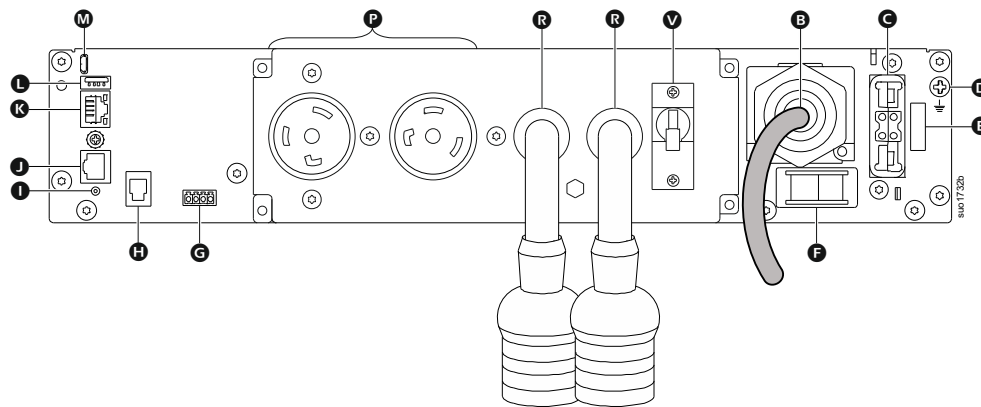

SRTL5KRM2UT-HW/SRTL5KRM2UJ-HW

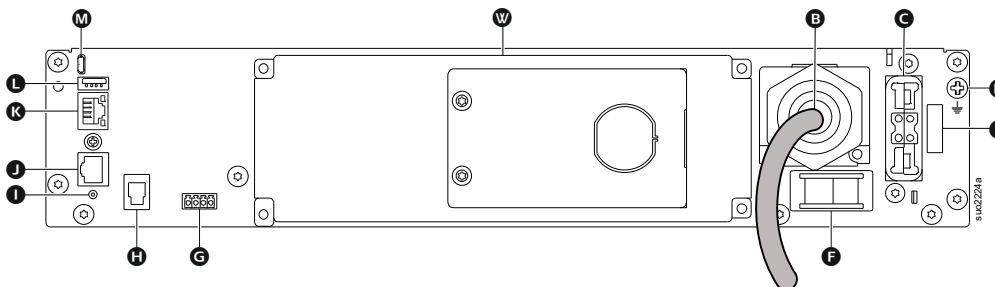

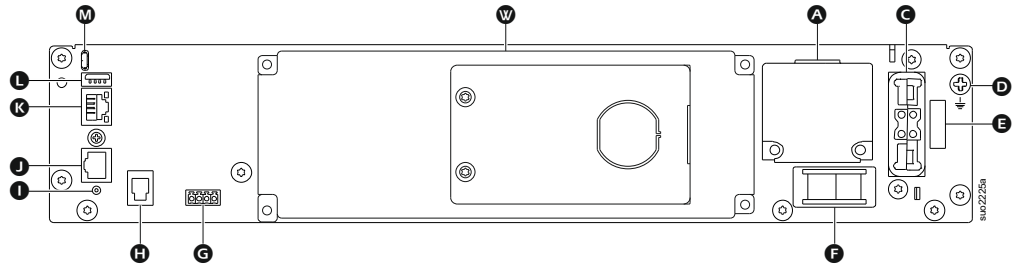
SRTL5KRM2UI-HW**Key to identify rear panel features**

A	Input hardwire terminal box	Hardwire the mains input.
B	AC input power cord	Connect the power cord to AC Mains.
C	External battery pack receptacle	Connect external battery pack(s) for extended run time. The UPS will automatically recognize up to 10 external battery packs.
D	Chassis ground	For ground connection of the XLBP.
E	Safety Interlock Switch	Battery Enable/Disable switch
F	System Enable Switch	System Enable/Disable switch.
G	EPO terminal	Emergency Power Off (EPO) terminal allows the user to connect the UPS to a central EPO system.
H	External battery pack communication port	Communication between XLBP and UPS.
I	RESET switch	Use this switch to reset network management interface.
J	Universal I/O port	Use to connect: <ul style="list-style-type: none"> • Temperature sensor AP9335T (supplied) • Temperature/humidity sensor AP9335TH (not supplied) • Relay input/output board AP9810 (not supplied).
K	Network port	Use the Network port to connect the UPS to the network. NOTE: Use a shielded cable for this connection.
L	Host USB port	For a USB Flash Drive.
M	Console port	Use the Console port to configure the network management features.
N	IEC C13 outlets	Use to connect the load.
O	IEC C19 outlets	
P	L6-30R outlets	
Q	L6-20R outlets	
R	Pigtail with L6-20R outlets	

Ⓢ	16 A output circuit breaker for IEC C19 outlets	Protects outlets in the event an overload condition occurs. Connected load should be lower than the circuit breaker capacity.
Ⓣ	10 A output circuit breaker for IEC C13 outlets	
Ⓤ	20 A output circuit breaker for L6-20R outlets	
Ⓥ	20 A output circuit breaker for pigtail with L6-20R outlets	
Ⓦ	Output hardwire terminal box	Use to connect the load.

Hardwiring

CAUTION

RISK OF ELECTRIC SHOCK

- Adhere to all national and local electrical codes.
- Use snap-In strain relief(s).
- The UPS must be wired into a branch circuit, equipped with a circuit breaker rated as specified in the tables below.
- Wiring should be performed by a qualified electrician.
- Actual wire size must comply with required amp capacity and national and local electrical codes.
- Disconnect the mains input circuit breaker before installing or servicing the UPS.
- Disconnect internal and external batteries before installing or servicing the UPS.
- The UPS contains internal and external batteries that may present a shock hazard even when disconnected from the mains.
- UPS outlets may be energized from remote.
- Disconnect equipment from the UPS before servicing any equipment.
- Do not use the UPS as a safety disconnect.
- Recommended input terminal screw torque: 16 lbf-in (2 Nm).

Failure to follow these instructions can result in equipment damage and minor or moderate injury

Wiring Specifications

Model	Input Voltage	Nominal input current	External input circuit breaker, (typical)	Input wire size, typical†
SRTL5KRM2UI SRTL5KRM2UI-HW	220/230/240 V	27 A	40 A / 2-pole	Refer to “Wire Size” on page 9 for details.
SRTL5KRM2UT SRTL5KRM2UT-HW	208/240 V	24 A	30 A / 2-pole	
SRTL5KRM2UJ SRTL5KRM2UJ-HW	200 V	24 A	30 A / 2-pole	

† L6-30 power cords are inbuilt.

Input Hardwiring

NOTE: Applicable only to SRTL5KRM2UI and SRTL5KRM2UI-HW.

Connections

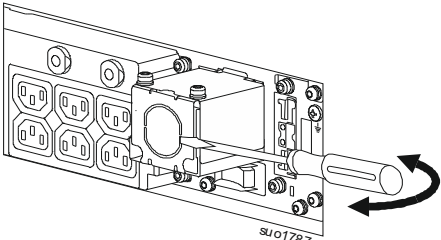
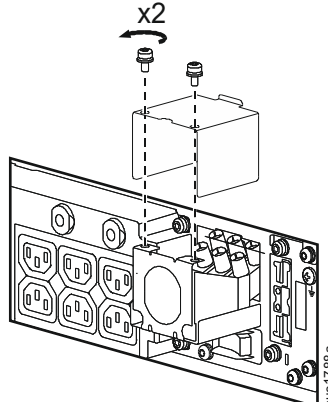
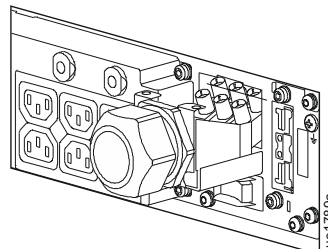
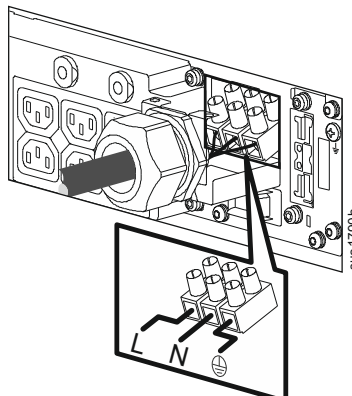
<p>SRTL5KRM2UI SRTL5KRM2UI-HW</p>	<p>Refer to "Input Connections" on page 9 for details.</p>
<p>1</p>	<p>Locate the hardwire input box.</p>
<p>2</p>	<p>Remove the knock out.</p> 
<p>3</p>	<p>Locate the screws securing the cover of the hardwire input box and remove the screws.</p> 
<p>4</p>	<p>Install the snap-in-strain relief on the hardwire input box.</p> 
<p>5</p>	<p>Insert the input wire through the strain relief and connect the wires securely to the input terminals.</p> <p>NOTE: Tightening Torque: 17 lbf-in (2 Nm).</p> 

Output hardwire

NOTE: Applicable only for SRTL5KRM2UT-HW, SRTL5KRM2UI-HW, and SRTL5KRM2UJ-HW models.

Model	Wire size, typical
SRTL5KRM2UI-HW	Refer to "Wire Size" on page 9 for details.
SRTL5KRM2UT-HW	
SRTL5KRM2UJ-HW	

Connections

Model	Wire size, typical
SRTL5KRM2UT-HW	Refer to "Output Connections" on page 9 for details.
SRTL5KRM2UJ-HW	
SRTL5KRM2UI-HW	

NOTE: SRTL5KRM2UI-HW has been used for the purpose of illustration. The procedure is the same for SRTL5KRM2UT-HW and SRTL5KRM2UJ-HW models also.

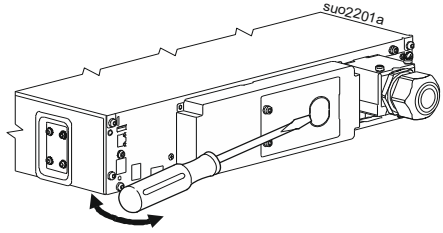
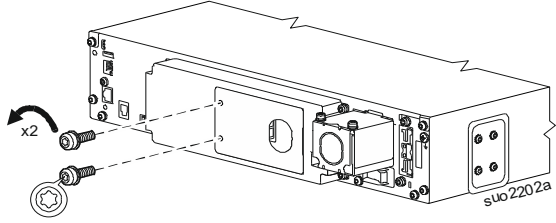
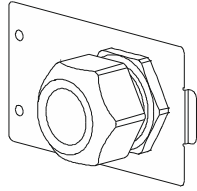
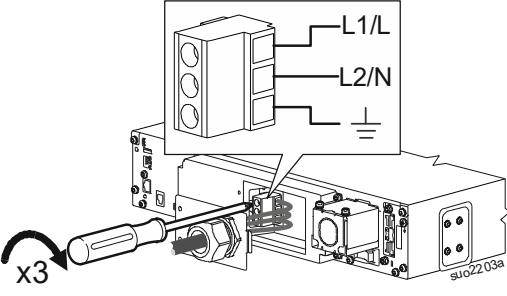
<p>1 Remove the knock-out.</p>	
<p>2 Locate the screws securing the PDU cover and unfasten the screws using a Torx® T20 driver bit.</p>	
<p>3 Install the strain-relief on the PDU cover.</p>	
<p>4 Insert the wire through the strain-relief and secure the wires to the terminals.</p> <p>NOTES: Be sure to connect the Line1/Line wire to the top terminal; the Line2/Neutral wire to the middle terminal; and the ground wire to the bottom terminal. Tightening Torque: 17 lbf-in (2 Nm).</p>	

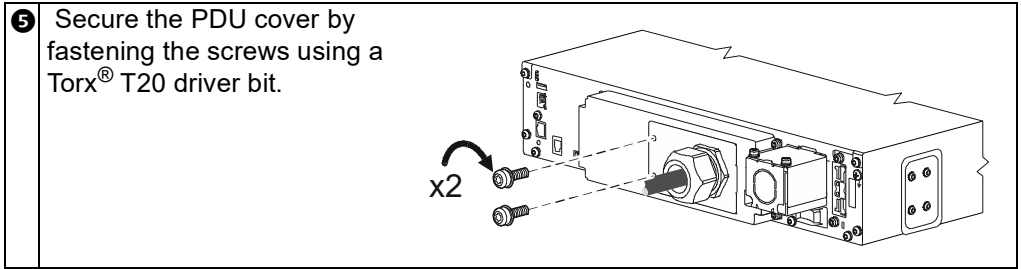

UPS Configuration

Connect Emergency Power Off feature

Install Ferrite Bead

The supplied ferrite bead must be installed between the EPO terminal block and the EPO switch.

NOTE: Be sure that two (2) turns of the wires are wound on the Ferrite Bead.

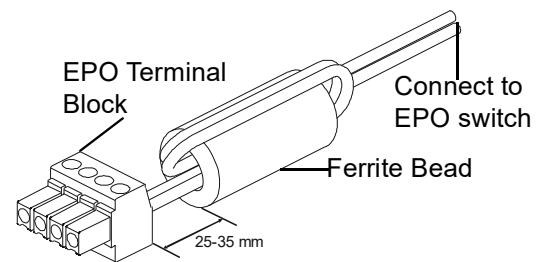

Normally open contacts

1. If the EPO switch or relay contacts are normally open, insert the wires from the switch or contacts at pins 1 and 4 of the EPO terminal block. Use 16-28 AWG wire.
2. Tighten the screws to secure the wires.

If the contacts are closed, the UPS will turn OFF and power will be removed from the connected equipment.

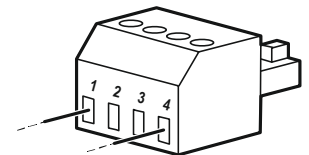

Normally closed contacts

1. If the EPO switch or relay contacts are normally closed, insert the wires from the switch or contacts at pins 1 and 2 of the EPO terminal block. Use 16-28 AWG wire.
2. Insert a wire jumper between pins 1 and 4. Tighten the screws of pins 1, 2, and 4 to secure the wires.

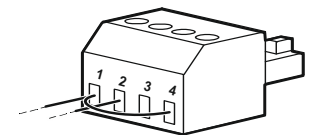

If the contacts are opened, the UPS will turn *off* and power will be removed from the connected equipment.

NOTE: Pin 4 is the power source for the EPO circuit, it provides a few milliamperes of 24 V power.

If the normally closed (NC) EPO configuration is used, the EPO switch or relay should be rated for “dry” circuit applications. The switch or relay contact rating should be for low voltage and low current applications. This normally implies the contacts are gold plated.

The EPO interface is a Safety Extra Low Voltage (SELV) circuit. Connect the EPO interface only to other SELV circuits. The EPO interface monitors circuits that have no determined voltage potential. SELV circuits are controlled by a switch or relay properly isolated from mains power. To avoid damage to the UPS, do not connect the EPO interface to any circuit other than a SELV circuit.

Use one of the following cable types to connect the UPS to the EPO switch.

- CL2: Class 2 cable for general use.
- CL2P: Plenum cable for use in ducts, plenums, and other spaces used for environmental air.
- CL2R: Riser cable for use in a vertical run in a floor to floor shaft.
- CLEX: Limited use cable for use in dwellings and for use in raceways.
- Installation in Canada: Use only CSA certified, type ELC, (extra low voltage control cable).
- Installation in countries other than Canada and the USA: Use standard low voltage cable in accordance with national and local regulations.

Configure main outlets

To configure the main outlet features, use the **Advanced** menus on the display interface and navigate to: **Main Menu > Configuration > Main Outlet**.

LCD Display Interface

A MENU key	
B Battery status icon	
C Battery charging icon	
D Green mode icon	
E Operation mode icon	
F UP key	
G UPS status information	
H DOWN key	
I Mute icon	
J Load icon	
K OK key	
L POWER button with LED	
M Status LED (located on the side of the UPS LCD display interface)	

- Press the button to wake up the UPS, when it is off state.
 - A short press of the button will display the control menu. Follow the prompts on the screen to either turn the UPS *on/off* immediately or after a delay. Button illumination indications are the same as the **Status LED**.
- Not illuminated: UPS output is off.
 - Illuminates steady green: UPS is on-line mode.
 - Illuminates red, blinks every 2 seconds: UPS is on-line mode and battery is disconnected.
 - Illuminates steady amber: UPS is in battery mode.
 - **Illuminates steady red: UPS has detected an internal error.**

LCD Display interface rotation

The orientation of the LCD display interface gets adjusted automatically based on the orientation of the UPS.

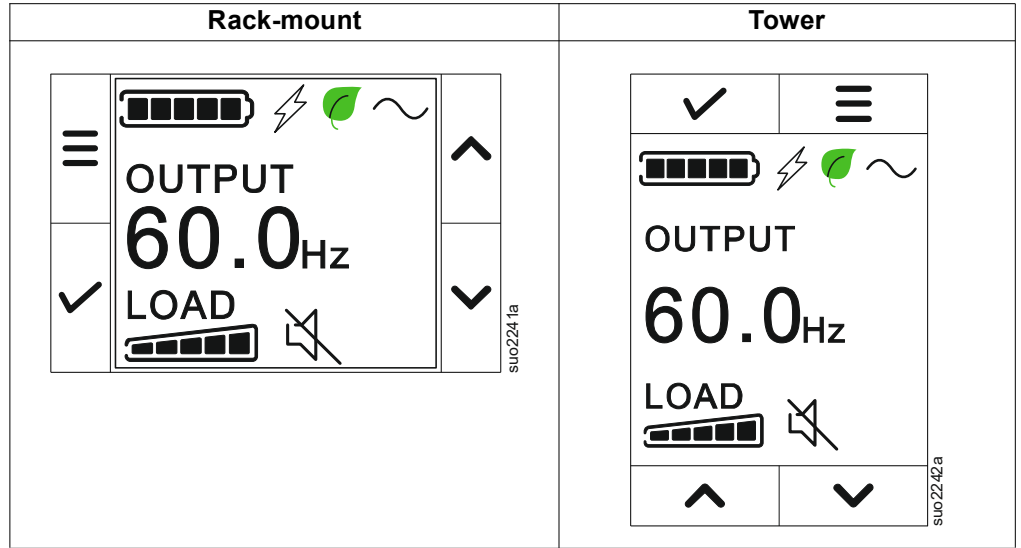

LCD Display Interface operation

The LCD display interface is a touchscreen interface.

Touch the icon to activate the key function.

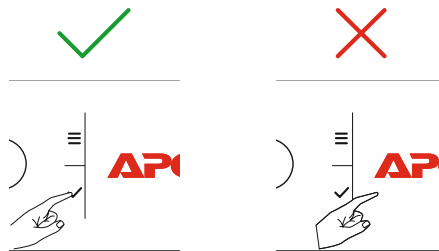

Use the UP/DOWN buttons to scroll through the options. Touch the OK key to accept the selected option. Touch the ESC key to return to the previous menu.

UPS Status Information

The status information field provides key information on the status of the UPS.

The **Standard** menu will allow the user to select one of the four screens listed below. Use the UP/DOWN buttons to scroll through the screens.









The **Advanced** menu will scroll through the four screens automatically.

- Input Voltage
- Output Voltage
- Output Frequency
- Runtime

In the case of an UPS event, status updates will be displayed defining the event or condition that has occurred.

The display screen illuminates amber to indicate a warning and red to indicate an alarm depending on the severity of the event or condition.

The icons on the LCD display interface screen may vary depending on the installed firmware version.

	Load icon: The approximate load capacity percentage is indicated by the number of illuminated load bar sections. Each bar represents approximately 16% of the load capacity.
	Mute icon: Indicates the audible alarm is disabled/muted.
Operation Mode Icons	
	On-Line mode: The UPS is supplying conditioned mains power to connected equipment.
	Bypass mode: In Bypass mode, the connected equipment will receive mains power as long as the input voltage and frequency are within the configured limits.
	Green mode: In Green mode, the connected equipment will receive mains power directly. In the event of a mains power outage, there will be an interruption in power to the connected equipment (up to 10 ms) while the UPS switches to On-Line mode or Battery mode. When enabling Green mode, consideration should be given to devices that may be sensitive to power fluctuations.
	Battery mode: The UPS is supplying battery power to connected equipment.
	UPS output off: The UPS is not supplying power to the connected equipment.
Battery Status Icons	
	Battery Charge Status: Indicates the battery charge status. Each illuminated bar represents approximately 20% charge.
	Battery Charge In Progress: Indicates the battery is charging.

Menu overview

The LCD display Interface has **Standard** and **Advanced** menu screens. The preference for **Standard** or **Advanced** menu selections is made during initial installation and can be changed at any time through the **Configuration** menu.

The **Standard** menus include the most commonly used options.

The **Advanced** menus provide additional options.

Note: Actual menu screens may differ by model and firmware version.

UPS Battery Replacement

⚠ CAUTION

RISK OF DAMAGE TO EQUIPMENT OR PERSONNEL

- The equipment is heavy. Always practice safe lifting techniques adequate for the weight of the equipment.
- Be sure to hold the battery module with both hands while sliding the battery module in and out.
- Adhere to all local and national electrical codes.
- Use the handle on the front face of the battery module to slide the battery modules in and out.
- Do not use the handle to lift or carry the battery module.

Failure to follow these instructions could result in equipment damage and minor or moderate injury.

- ❶ Remove the front bezel.

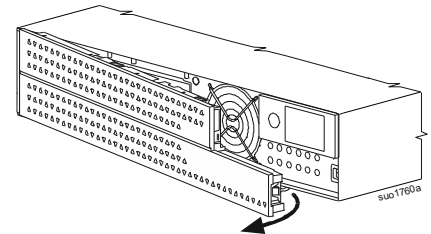

- ❷ Turn the BATTERY ON/OFF switch in clockwise direction, using a screwdriver, to switch *off* the battery.

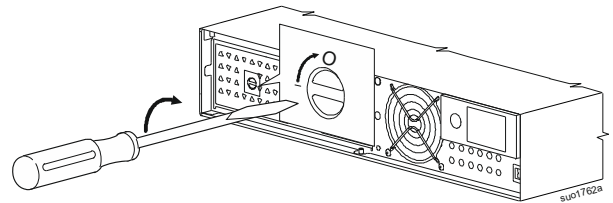

- ❸ Turn the thumbscrew in counter clockwise direction to unlock the battery module.

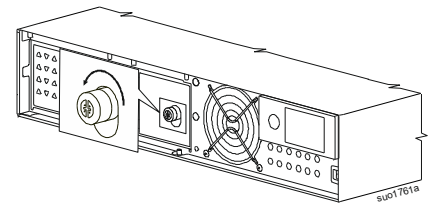

<p>4 Push down and hold the thumbscrew and slide out the battery module. NOTE: Be sure to support the battery module with both hands while sliding out the battery module.</p>	
<p>5 Slide the replacement battery module into the UPS till it gets locked in position. NOTE: Be sure to support the battery module with both hands while sliding in the battery module</p>	
<p>6 Press the thumbscrew till it engages and turn it in clockwise direction to lock the battery</p>	
<p>7 Turn the BATTERY ON/OFF switch in counter clockwise direction, using a screwdriver, to switch on the battery.</p>	

Location of QR Code for Operation Manual

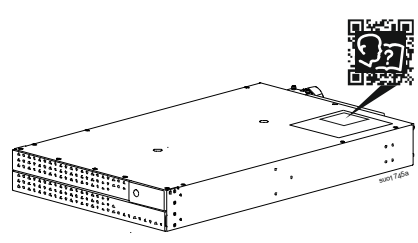

Locate the QR code and scan it for downloading the Operation Manual

ENERGY STAR®



Select models are ENERGY STAR qualified.

For more information on your specific model refer to our web site, www.apc.com.